

RAHMENGEOMETRIEN / GÉOMÉTRIE VÉLO

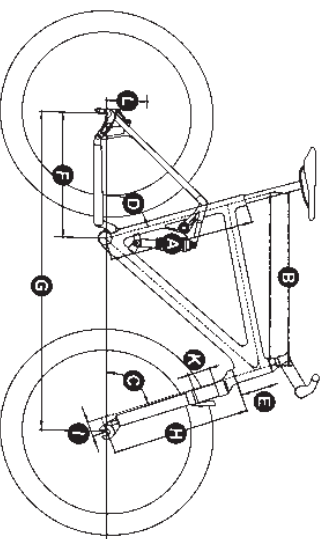

- A Rahmengröße
 B Oberrohrlänge horizontal
 B' Oberrohrlänge effektiv
 C Steuerrohrwinkel
 D Sitzrohrwinkel
 E Steuerrohrlänge
 F Kettenstrebenlänge
 G Radstand
 H Gabelbauhöhe
 I Gabelvorbiegung
 K Federweg Gabel
 L Federweg Hinterbau

SLR MARATHON Seite 7

A	B	C	D	E	F	G	H	I	K	L	
42	420	570	69°	72°	110	430	1067	485-525	39	100-140	140
47	470	592	69°	72°	120	430	1092	485-525	39	100-140	140
52	520	615	69°	72°	130	430	1117	485-525	39	100-140	140

F-ZERO Seite 9

A	B	C	D	E	F	G	H	I	K	L	
16"	406	561	68,5°	72°	130	443	1088	501-511	39	120-140	114
18"	457	588	68,5°	72°	140	443	1115	501-511	39	120-140	114
20"	510	605	68,5°	72°	150	443	1133	501-511	39	120-140	114
22"	559	615	68,5°	72°	160	443	1144	501-511	39	120-140	114

SLR Seite 11

A	B	C	D	E	F	G	H	I	K	L	
42	420	565	71°	72°	120	430	1038	485	39	100-120	90
47	470	585	71°	72°	120	430	1058	485	39	100-120	90
52	520	605	71°	72°	140	430	1078	485	39	100-120	90

Seven Seite 13

A	B	C	D	E	F	G	H	I	K	L	
S	430	575	71°	73°	110	425	1049	475	39	100	100
M	470	590	71°	73°	115	425	1064	475	39	100	100
L	510	612	71°	73°	130	425	1087	475	39	100	100

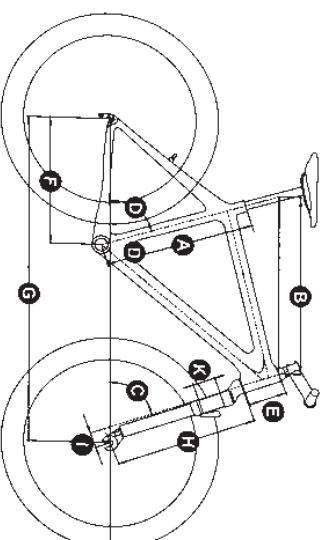

Equipe XC Seite 15 | Street RC Seite 20

A	B	C	D	E	F	G	H	I	K	L
17"	432	560	70°	73,5°	120	420	1047	451	39	100
19"	483	582	70°	73,5°	135	420	1070	451	39	100
21"	533	618	70°	72,5°	135	420	1095	451	39	100
23"	584	618	70°	72,5°	145	420	1096	451	39	100

Sienna Seite 17

A	B	C	D	E	F	G	H	I	K	L
15"	381	530	70,5°	73,5°	120	430	1020	451	38	100
17"	432	556	70,5°	73,5°	130	430	1047	451	38	100
19"	483	582	70,5°	73,5°	145	430	1074	451	38	100

Elite XC Seite 19

A	B	C	D	E	F	G	H	I	K	L
16"	407	550	70°	73,5°	104	420	1037	475	39	100
17"	432	570	70°	73,5°	111	420	1058	475	39	100
18"	457	590	70°	73,5°	118	420	1078	475	39	100
19"	483	610	70°	73,5°	125	420	1099	475	39	100
20"	508	630	70°	73,5°	132	420	1119	475	39	100

Striker Seite 21 | Viper Seite 22 | Hawk Seite 23

A	B	C	D	E	F	G	H	I	K	L
13"	330	520	71,5°	73°	110	425	987	420	38	80
15"	381	570	71,5°	73°	110	425	1037	420	38	80
17"	432	579	71,5°	73°	120	425	1047	420	38	80
19"	483	588	71,5°	73°	130	425	1057	420	38	80
21"	533	588	71,5°	73°	140	425	1056	420	38	80
23"	584	602	71,5°	73°	155	425	1071	420	38	80

Stratos, Cosmic Seite 25		Valiant, Atlanta Seite 26		Light city Seite 27						
RH-TYP	A	B"	C	D	E	F	G	H	I	
46	Lady c/SP	460	579	71°	73°	150	450	1102	442	45
50	Lady c/SP	500	583	71°	73°	160	450	1106	442	45
54	Lady c/SP	540	589	71°	73°	170	450	1110	442	45
50	Men	500	577	71°	73°	150	450	1099	442	45
54	Men	540	577	71°	73°	170	450	1097	442	45
58	Men	580	580	71°	73°	190	450	1099	442	45
61	Men	610	591	71°	73°	190	450	1106	442	45

City Cross Seite 24		Texas Seite 29								
RH-TYP	A	B	C	D	E	F	G	H	I	
46	Lady SP	460	574	71°	73°	150	450	1063	445	38
50	Lady SP	500	594	71°	73°	160	450	1083	445	38
54	Lady SP	540	607	71°	73°	170	450	1097	445	38
58	Lady SP	580	616	71°	73°	180	450	1097	445	38
48	Men	480	594	71°	73°	150	450	1083	445	38
52	Men	520	609	71°	73°	170	450	1098	445	38
56	Men	560	614	71°	73°	180	450	1103	445	38
60	Men	600	627	71°	73°	200	450	1111	445	38

Swissa Seite 33										
RH-TYP	A	B"	C	D	E	F	G	H	I	
46	Lady cl	460	566	71°	73°	160	460	1098	445	45
50	Lady cl	500	567	71°	73°	160	460	1098	445	45
54	Lady cl	540	570	71°	73°	160	460	1098	445	45

Luxor Seite 34										
RH-TYP	A	B"	C	D	E	F	G	H	I	
46	Lady c/SP	460	579	71.5°	73.5°	150	445	1098	450	45
50	Lady c/SP	500	580	71.5°	73.5°	160	445	1103	450	45
54	Lady c/SP	540	580	71.5°	73.5°	170	445	1103	450	45
50	Men	500	574	71.5°	73.5°	150	445	1095	442	45
54	Men	540	574	71.5°	73.5°	170	445	1095	442	45
58	Men	580	575	71.5°	73.5°	190	445	1096	442	45

Trentina 26" Seite 35										
RH-TYP	A	B	C	D	E	F	G	H	I	
46	Lady cl	460	566	71°	73°	160	430	1068	445	45
50	Lady cl	500	567	71°	73°	160	430	1068	445	45
54	Lady cl	540	570	71°	73°	160	430	1068	445	45

Calanca 26" Seite 30										
RH-TYP	A	B"	C	D	E	F	G	H	I	
46	Lady c/SP	460	584	71°	73°	150	450	1102	442	45
50	Lady c/SP	500	590	71°	73°	160	450	1106	442	45
54	Lady c/SP	540	598	71°	73°	170	450	1110	442	45
50	Men	500	583	71°	73°	150	450	1099	442	45
54	Men	540	584	71°	73°	170	450	1097	442	45
58	Men	580	589	71°	73°	190	450	1099	442	45

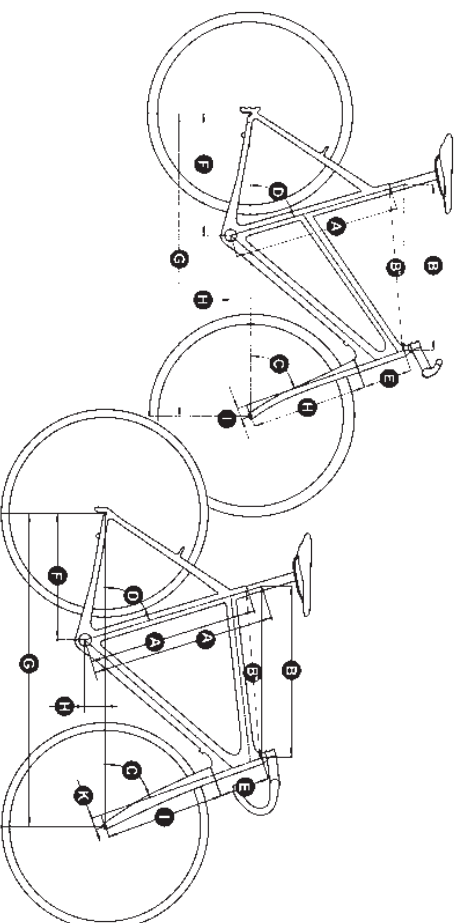

Light Cross Seite 28									
A	B"	C	D	E	F	G	H	I	
51	510	520	72°	74°	138	415	988	372	44
53	530	534	72.5°	73.5°	157	415	982	372	44
55	550	543	72.5°	73.5°	167	415	1002	372	44
57	570	559	73°	73.5°	187	415	1010	372	44
59	590	565	73°	73.5°	204	415	1012	372	44

CPD 01 Seite 36									
A	B"	C	D	E	F	G	H	I	
53	530	535	72.5°	73.5°	157	405	984	372	44
55	550	545	72.5°	73.5°	167	405	992	372	44
57	570	561	73°	73°	187	407	1002	372	44
59	590	571	73°	73°	204	407	1012	372	44
61	610	577	73°	73°	225	407	1018	372	44
63	630	590	73°	73°	225	407	1027	372	44

MCC 05 Seite 36									
A	B"	C	D	E	F	G	H	I	
53	530	528	72.5°	73.5°	157	405	984	372	44
55	550	546	72.5°	73.5°	167	405	992	372	44
57	570	563	73°	73°	187	407	1002	372	44
59	590	579	73°	73°	204	407	1012	372	44

MCD 03 Seite 37									
A	B"	C	D	E	F	G	H	I	
49	490	545	72°	73.5°	120	405	993	355	45
52	520	560	72.5°	73°	145	405	999	355	45
55	550	575	72.5°	72.5°	170	405	1109	355	45
58	580	590	72.5°	72.5°	195	405	1024	355	45